

FORCE Fusion Gas Spring Relocation

Follow the instructions below to relocate your gas spring from the left side of the game to the right side. Relocating the gas spring will provide greater ease in locking the bezel and put less stress on the gas spring.

NOTE: Only the short gas springs can be relocated. Please refer to Figure 1 to determine if you have a short or long gas spring.

1. Turn off and unplug the game.
2. Unlock and open the monitor bezel.
3. Verify that the one-inch reference block on the supplied sheet labeled PM0507-01 measures 1 inch.* Then, carefully cut the two templates from the supplied sheet labeled PM0507-01.
4. Place the supplied upper template as shown in Figure 1. Make sure the marked edges of the template are lined up with the edge of the hinge and the coin mech cutout in the wood bezel. The text on the template should be visible (face up) when the template is in place.

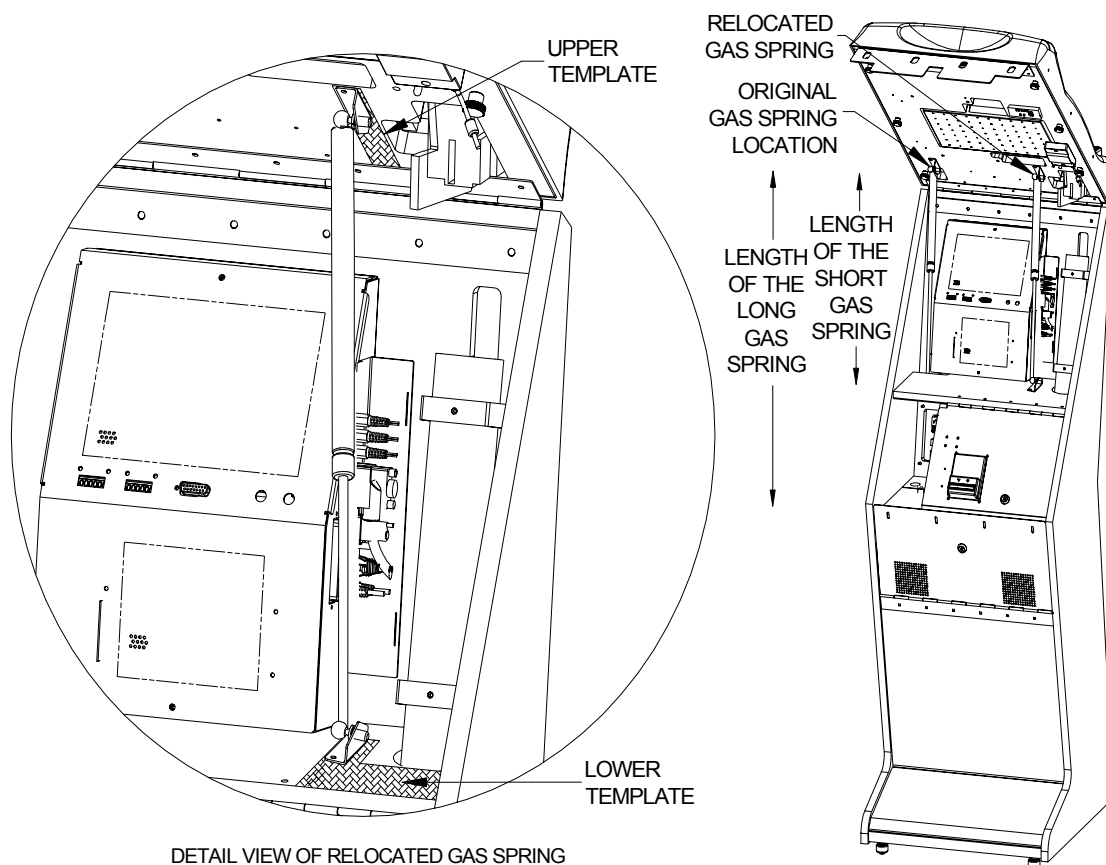
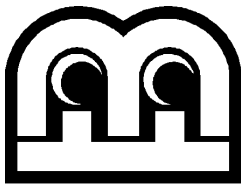

FIGURE 1 – GAS SPRING LOCATION IN FUSION GAME

* If the reference block in the printed template does not equal one inch, reprint the template. This time, make sure that the option to shrink oversized pages is not checked.



5. Drill two pilot holes through the two holes marked on the template.
6. Place the supplied lower template as shown in Figure 1. Align the marked edge of the template with the front and right edge of the shelf. The text on the template should be visible (face up) when the template is in place.
7. Drill two pilot holes through the two holes marked on the template.
8. Locate the wire safety clip at each end of the gas spring. While supporting the bezel, unclamp the circular part of the wire safety clip by pushing the clip away from the neck of the end fitting (see Figure 2). Then, remove the clip by pulling the straight end of the clip out of the end fitting. Repeat for the other end of the gas spring.



FIGURE 2 – CLOSE-UP VIEW OF THE END OF THE GAS SPRING

9. While supporting the bezel, carefully snap one side of the end fitting out of the ball mounting stud on the mounting bracket. Repeat for the other side of the gas spring.
10. If you are installing new gas spring mounting brackets, continue with step 12.
11. Remove the hardware securing the metal mounting brackets in the game and remove the brackets.
12. Line up one of the brackets with the pilot holes and secure it using the hardware. Repeat for the other bracket.
13. Snap the end fitting on the gas spring over the ball mounting stud in the bracket. Repeat for the other side of the gas spring.
14. Secure the ball stud on the end of the gas spring by inserting the straight end of one of the wire safety clips up through the small hole to the right of the ball stud as shown in Figure 2. Then, clamp the circular part of the clip around the neck of the end fitting. Repeat for the other end of the gas spring.
15. Close and lock the bezel. Be careful the first time you close the bezel as you familiarize yourself with the functionality of the gas spring.
16. Plug in and turn on the game.

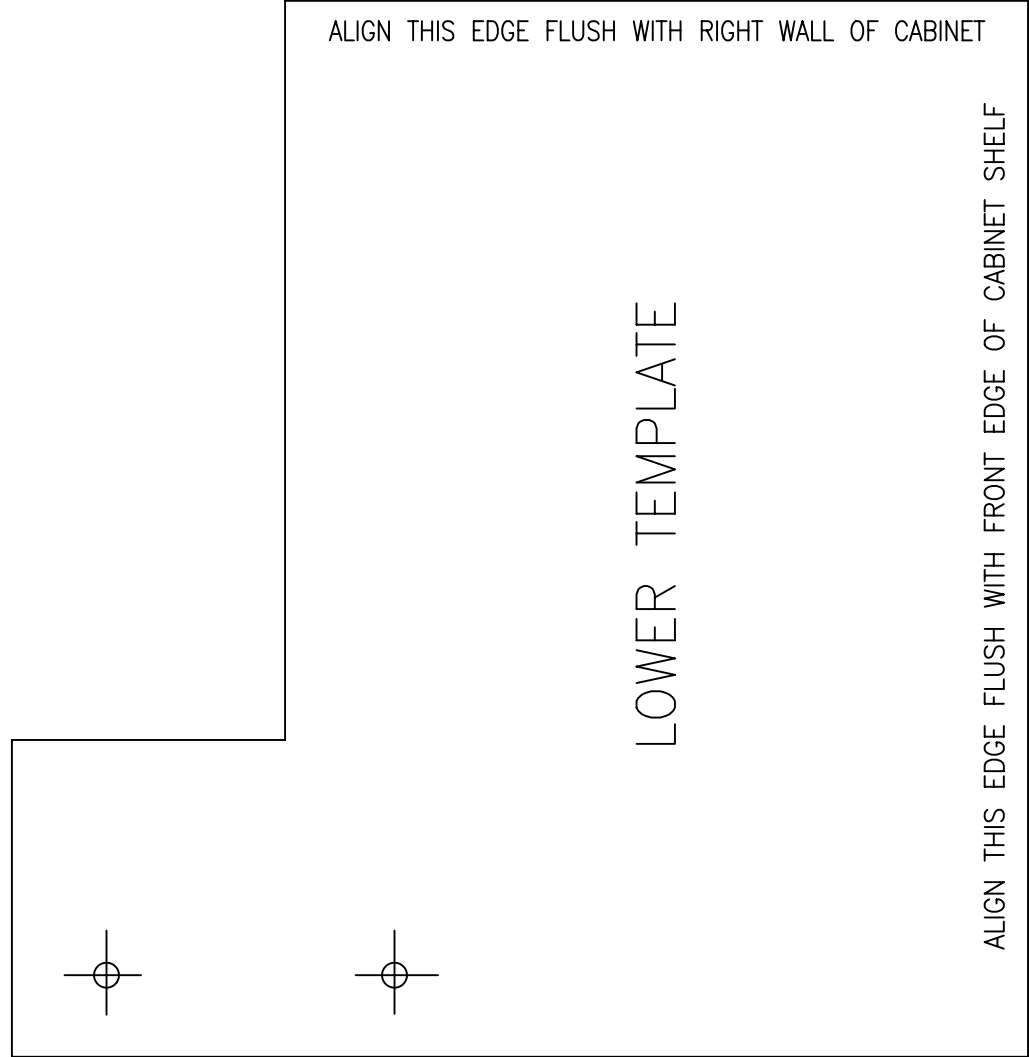
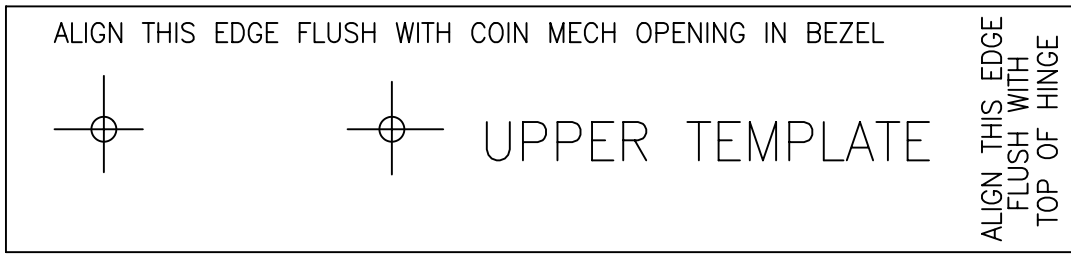

1" SCALE
REFERENCE
BLOCK

merit industries, inc.	
TITLE	GAS SPRING RELOCATION TEMPLATE
SIZE	A
DRAWING/PART NO.	PM0507-01
ISSUE	REV LETTER
SCALE	NONE
E/D/F	-
SHEET 1 OF 1	

THIS ITEM AND/OR THE INFORMATION CONTAINED THEREIN IS AND REMAINS THE SOLE PROPERTY OF AND IS PROPRIETARY TO, MERIT INDUSTRIES (MI). THIS ITEM AND/OR INFORMATION SHALL BE KEPT CONFIDENTIAL AND MAY NOT BE REPRODUCED, COPIED, MODIFIED, DISCLOSED, TRANSFERRED OR MADE AVAILABLE TO OTHERS, EXCEPT WITH THE PRIOR, WRITTEN CONSENT OF MI. THIS ITEM AND/OR ALL COPIES, IF ANY, ARE SUBJECT TO RETURN TO MI.

ZONE	REV LEVEL	ECO #	DESCRIPTION	FOR DETAILS SEE	ECO	DFTR	CHK	DATE	APPVD
-	-	---	ENGINEERING RELEASE			RCS		2/10/06	
REVISIONS									

DO NOT SCALE THIS PRINT