

Site Preparation

In determining the location for your Megatouch XL 6000 video game, consideration must be given to a suitable, grounded electrical outlet. Since the game is a computerized device, it should have a separate circuit, if at all possible. If a separate circuit is not available, care should be taken to provide a clean and constant voltage. As a basic guideline, never connect the unit to a circuit that also supplies power to freezers, coolers or other high power consuming and electrical noise generating equipment.

Game Description

The Megatouch XL comes housed in a 13" countertop cabinet, a 19" cabaret cabinet or a 19" upright cabinet.

The countertop model has 4 key-locked compartments: the CPU section, the CD-ROM access, the coin mech section and the coin box. The upright and cabaret models also have 4 key-locked compartments: the CPU section, the coin mech section, the coin box and the rear door. The countertop is equipped with one coin mech and the upright and cabaret models have two; optional bill acceptors are available for all models.

CD-ROM Compartment (countertop model only)

Located on the left side of the game, the CD-ROM door allows access to the CD-ROM player.

Rear Door Compartment (upright/cabaret models)

The rear compartment of the 19" upright allows access to the rear of the monitor, the communications board and the touchscreen controller

CPU Section

The CPU section is accessible from the rear of the unit in the countertop and from the front of the upright and cabaret versions. In the countertop, The CPU section houses the CRT, the monitor controls, the CPU and CRT-500 I/O boards, the power supply and the main harness; in the upright and cabaret versions, the CPU section houses the CPU and

CRT-500 I/O boards, the power supply, the main harness, the CD player and volume control.

The Dallas key and boot PROM are located on the CRT-500 I/O board, as is the volume control for the countertop version. The volume control for the upright and cabaret models, is located at the front of the PC shelf (see Figures 10, 11 and 13 for locations).

Coin Mech/Coin Box Section

13" Countertop

The coin mech/coin box section is accessible from the front of the unit. This section is key-locked for security purposes. A sturdy metal box located within the coin mech section, holds all coins deposited into the machine. The coin box is separately key-locked for security.

Also located within the cavity of the coin mech are 2 internal switches, "SETUP" and "CALIBRATE," and the coin meter. Location of these switches can be seen in Figure 10. Pressing the "SETUP" button will bring you to the Megatouch Setup screen (see Figure 1). See the next section for calibration instructions.

19" Upright/19" Cabaret

The coin mech and coin box are accessible from the front of the cabinet. Both doors are key-locked for security purposes.

Also located within the cavity of the coin mech are 2 internal switches, "SETUP" and "CALIBRATE," and the coin meter. Location of these switches can be seen in Figures 11 and 13. Pressing the "SETUP" button will bring you to the Megatouch Setup screen (see Figure 1). See the next section for calibration instructions. The remote monitor controls are also located inside the coin mech section, Velcroed to the top of the coin box.

Screen Calibration

The machine must be in the idle mode or game select mode to calibrate the touchscreen.

- Find the “CALIBRATE” button located behind the coin mech and press it to enter the screen calibration mode.
- Touch the center of the first circle that appears on the screen. Once you release your finger, a second circle will appear on the screen.

NOTE: YOU MUST HOLD YOUR FINGER ON THE CIRCLE FOR APPROXIMATELY 2 SECONDS FOR THE CALIBRATION TO BE RECOGNIZED.

- Touch the center of the second circle that appears on the screen.
- Once the second circle is touched, a crosshair will appear on the screen. To test the calibration of the screen, touch the crosshair with your finger and slowly drag your finger around the screen. The crosshair should follow your movement.
- Touch the “EXIT TEST” icon.

NOTE: On upright models, if you open the monitor door while the machine is on, you will have to recalibrate the touchscreen.

Degaussing your Monitor

If your monitor is displaying “purity problems,” (a display with purity problems will have parts of an all-white screen affected by blotches of color) the monitor needs to be degaussed using a “degaussing coil.” A degaussing coil is a circular electromagnet, used to cancel out any stray magnetic fields that may build up on a metal object.

All of our monitors have built-in degaussing coils that are automatically activated on power-up. If your game is experiencing minor purity problems, try powering down the game for 5 minutes and then reapplying power to activate the degaussing coil. If the problem is not corrected, you will have to use a manual-degaussing coil.

Follow the instructions below for degaussing a monitor.

1. Plug in your degaussing coil.

2. Hold the coil about three feet from the monitor, press the trigger to activate the magnetic field (for circular-shaped coils, orient the coil so you see the monitor through the hole in the middle; for wand-shaped coils, point the wand towards the screen).
3. Move the coil in a circular motion around the face of the monitor and slowly approach the game.
4. Continuing to move the coil in a circular motion, slowly back away from the monitor.
- 5a. CIRCULAR-SHAPED COILS: When you are about three feet away, quickly turn the coil perpendicular to the monitor and release the trigger.
- 5b. WAND-SHAPED COILS: When you are about three feet away, point the wand away from the monitor and release the trigger.

Monitor Colors Adjustment Procedure

For adjusting the colors on any of our monitor types, we suggest following the procedures described below.

The vertical/horizontal controls and brightness/contrast controls are located on the monitor control panel, Velcroed inside the game. The monitor RGB controls are located on the monitor neckboard. Adjust the RGB controls until the screens look as suggested in the following steps.

Ducksan/Telco/Tatung Monitors

1. Set the game to the Checkerz game screen.
2. Adjust the vertical and horizontal size and vertical and horizontal position to make sure that the game screen fills the monitor screen and that the game screen is centered.
3. Adjust the brightness and contrast controls until the top sets of checkers are rich red and the bottom set are a dark gray. The feet on the “Checkerz” character should be white. (Adjusting the brightness and contrast can also correct for a lack of sharpness in the picture.)

Maintenance

Cleaning the Cabinet

- The cabinet should be cleaned with a damp cloth and mild detergent.

Cleaning the Touchscreen Monitor

- The touchscreen glass should be cleaned with a damp cloth and isopropyl alcohol or a *non-ammonia* cleanser. *Do not use any abrasive or vinegar-based cleansers, as they will damage the touchscreen glass.*

To gain access to the entire surface of the monitor screen on the upright model, you will have to release the monitor door latches. To do so, open the coin mech door. Located inside, above and to the right and left of the coin mech, are two monitor door latches. Loosen the thumbscrews securing the latches and rotate the latches to release the monitor door. See Figure 12.

To gain access to the entire surface of the monitor screen on the cabaret model, you will have to release the monitor door latches. To do so, open the coin mech door. Located inside, above and to the right and left of the coin mech, are two monitor door slide-latches. Loosen the thumb nuts securing the latch and slide the latch open. Pull up on the bottom of the bezel to remove it (NOTE: TO FULLY REMOVE THE BEZEL, YOU MUST DISCONNECT THE GROUND BRAID).

To gain access to the entire surface of the monitor screen on the countertop model, you will have to remove the top of the machine. To remove the top of the machine, unlock and open the rear door. Disconnect the fan power connector and disconnect the plastic tubing and ground strap attached to the lid. Press up on the spring-loaded levers located on each side of the lid. Push the lid forward and pick it up to remove. See the decal inside the lid for a diagram of locations.

NOTE: DO NOT USE ANY ABRASIVE SOLVENTS, ACID OR VINEGAR-BASED CLEANSERS ON THE MONITOR OR SIDE DECALS. OVER TIME, SUCH CLEANSERS COULD HARM THE TOUCHSCREEN AND ERASE THE DECALS. BE CAREFUL NOT TO USE COMMERCIAL CLEANERS CONTAINING ANY OF THESE SUBSTANCES.

Cleaning the Compact Disc and CD Player

- *It is extremely important that you clean both the compact disc and the CD-ROM unit in your Megatouch XL game. If the lens and/or the disc becomes too dirty it can cause a variety of failures with the game. We recommend cleaning the CD-ROM and disc approximately once every 90 days, or if any problems are experienced with the CD-ROM unit.*
- *CD cleaning supplies can be purchased from your local record store or audio supply house.*
- *To activate the game for use with a CD-ROM lens cleaner, turn off the game and set DIP Switch 2-1 to "ON." Turn on the game and follow the instructions displayed on the screen.*

If the CD-ROM unit should become too dirty, you may need to take it apart to clean it thoroughly. Should you need to do this, refer to the documentation that came with the CD-ROM unit.

Fan Operation

- To ensure proper operation of the game, it is important that all fans are operating correctly and that the airflow is unobstructed. Make sure nothing is placed inside the cabinet or next to the fan vents that would inhibit the flow of air. Also, if any fans are not operating, it is important that they be replaced.

Troubleshooting

Coin Jam

The game also has coin jam and stringing detection software. Should a coin become jammed in the mech or someone tries to string the mech, a continuous tone will be emitted by the game and the words "COIN JAM" will be displayed on the screen.

If the game emits the coin jam indicator sound when powered up, this may indicate that the NORMALLY CLOSED contacts of the coin mechanism are being used. The NORMALLY OPEN contacts must be used.

Also, see the accompanying Troubleshooting Guide.

Megatouch™ XL Software Instructions

DIP Switch Settings

Physical DIP switches are reserved for future use. All current operator-adjustable functions are controlled by the soft DIP switches (accessed by touching the "OPTIONS" icon on the Megatouch XL 6000 Setup screen. See Figure 1).

TIMER ¹	YES	NO	ALLOW SEX?	
	YES	NO	ALLOW NUDITY? ^{2/3}	
	YES	NO	ALLOW SEX DURING ATTRACT? ³	
	YES	NO	MYSTERY PHRAZE SEX CATEGORY? ³	
	YES	NO	MATCH'EM UP BABES AND HUNKS? ³	
	YES	NO	MEMOREE BABES AND HUNKS? ³	
	YES	NO	TRIVIA/POWER QUIZ SEX CATEGORY? ³	
	YES	NO	PIX MIX BABES AND HUNKS? ³	
	YES	NO	PHOTO HUNT EROTIC CATEGORY? ³	
	SET ⁴	NO	YES	PLAYER SELECTABLE LANGUAGE
		OTHER	ENG	DEFAULT LANGUAGE?
		YES	NO	LANGUAGE BUTTONS HAVE FLAGS
		YES	NO	SOLITAIRE FREE GAME?
		YES	NO	TRIVIA/PWR QUIZ SHOW CORRECT ANSWER?
		4/300K	5/1M	TRIVIA ROUNDS/BONUS?
YES		NO	POWER SOLITAIRE SPLIT COLUMN MOVE?	
YES		NO	POWER SOLITAIRE FREE GAME?	
\$/¢		CREDS	PRICE DISPLAY?	
YES		NO	STRIP POKER MOAN SOUNDS? ³	
YES		NO	STRIP POKER REWINDS FOR LOSS ³	
ENG		GER	CHECKERZ RULES?	
NO		YES	AUTO CLEAR HIGH SCORES ⁵	
NO		YES	6 STARS ENABLED?	
YES		NO	HI-SCORE ACCESS FROM 6 STARS? ⁶	
YES	NO	VBB ACCESS FROM 6 STARS? ⁶		
YES	NO	VOLUME CONTROL ACCESS FROM 6 STARS ⁶		
NO	YES	SHOW DECK CARDS		
SHORT	LONG	FAN TIME? ⁷		
YES	NO	ALLOW GAME CONTINUATION?		
YES	NO	ALLOW BONUS REPLAY? ⁸		
NO	YES	FREE PLAY ENABLED		
NO	YES	EASY MODE ENABLED ⁹		
NO	YES	POWER QUIZ CATEGORY SAME FOR ALL		
YES	NO	POWER QUIZ CONSOLATION QUESTION		
NO	YES	CONTINUOUS BONUS ROUND?		

¹ Touching "TIMER" for the "ALLOW SEX?" setting allows the operator to set times during which adult-oriented categories and games are available to the players. Using the arrows, set the time at which the adult-oriented games and categories will be turned on and set the time at which they'll be turned off. The time is set using 24 hour, "military" time. The factory default settings are set to turn on at 22:00 (10:00 PM) and to turn off at 6:00 (6:00 AM).

² When "ALLOW NUDITY" is set to "YES," a small box will appear to the right. Select from "R" or "X" rated nudity ("X-rated" = full frontal nudity).

³ These settings are only available if "ALLOW SEX?" is set to "TIMER" or "YES."

⁴ "SET" is only shown if "Player Selectable Language" is set to "YES." By touching the "SET" button, the Language Select Screen will be displayed. Use the "On" and "Off" button to select the desired language.

NOTE: The first language selected will automatically become the default language; all other languages will follow in the order that they are selected.

⁵ When "AUTO CLEAR HIGH SCORES" is set to "YES," a small box will appear to the right. Touching this box allows the time period to be set from 1 to 4 weeks (from the time the player name is entered). The factory default setting is two (2) weeks.

⁶ These settings are only available if "6 STARS ENABLED?" is set to "YES."

⁷ This setting is only available if "SHOW DECK CARDS" is set to "YES."

⁸ Setting this to "YES" enables a bonus replay for all games, except Trivia Whiz, Pile On, Strip Poker, Double Solitaire and Mystery Phraze. The table below shows the scores needed to achieve a bonus replay (after a replay has been earned, the next player must beat the last replay score to earn another replay).

Game Name	Score Needed for Initial Replay
Great Solitaire	45,000
Run 21	250,000
Royal Flash	300,000
Match'Em Up	200,000
Memoree	300,000
Tri-Towers*	125,000
4-Play	1,500,000
Conquest	30,000
11-Up*	125,000
Hoop Jones	125
Zip 21	200,000
Checkerz	28,000
Quik Match	400,000
Power Solitaire	55,000
Pix Mix	350,000
Photo Hunt	400,000
Quikcell	100,000
Tai Play	240,000
Puck Shot	3000
Take 2*	110,000
Mystery Phraze	325,000
Power Quiz	NO REPLAY
Pile On	NO REPLAY
Strip Poker	NO REPLAY
Double Solitaire	NO REPLAY
Trivia Whiz	NO REPLAY
Mega Link Trivia	NO REPLAY
Chug 21	250,000
Symbol Tri-Towers	125,000
Symbol 11-UP	125,000
Symbol Take - 2	110,000
Hooter	NO REPLAY
Trip Flip*	NO REPLAY
Tennis Ace	NO REPLAY
3 Blind Mice	NO REPLAY
Route 66	45,000
Super Route 66	55,000
Fast Lane	100,000

⁹ Easy Mode reduces the number of points needed to reach the bonus round for Hoop Jones (125/150 points), Eleven-Up (68,000/80,000 points), Tri-Towers (64,000/80,000 points), Royal Flash (180,000/200,000 points) and Quik Match (250,000/280,000 points).

Mega Link™ Feature

The Megatouch XL's Mega Link™ feature allows up to four games, in one location, to be linked together, allowing 2 to 4 players to play in head-to-head competition.

The Mega Link™ logo will appear next to each "linkable" game in the player's game menu. Selecting a "linkable" game brings up the "Mega Link™" icon, along with the standard "1 player" and "2 player" icons. If the game is not linked to other Megatouch XL games, the Mega Link™ icon will appear.

Mega Link Games

Mega Link Trivia*	Royal Flash
Quik Match	Take 2
Hoop Jones	Chug 21
Tri-Towers	Symbol Take 2
Checkerz	Symbol Tri-Towers
Solitaire	Symbol Eleven-UP
Power Solitaire	Puck Shot
Double Solitaire*	Pile On*
Eleven-Up	Tennis Ace
Run 21	Power Quiz
Zip 21	Super Route 66
Route 66	

*Can only be played as a linked game. If the game is not linked, these games will not appear in the player's game menu.

To link your games, connect one end of an RJ11 cable to one of the communications jacks located near the power entry and connect the other end to one of the communications jacks on the other game. You can repeat this, IN SERIES, for up to four (4) games. IT IS IMPORTANT THAT YOU DO NOT CONNECT THE GAMES IN A LOOP (i.e. DO NOT CONNECT THE LAST GAME IN YOUR SERIES TO THE FIRST GAME IN THE SERIES).

To Enter This Screen, Touch The “Setup” Button In The Coin Mech Section



Figure 1 - Megatouch Game Setup Screen

Setup Screen Functions

- Coin-In Menu: Enters the coin/credit setup screen.
- Game Menu: Enters the game menu selection screen.
- Display Books: Enters the bookkeeping statistics screen.
- Options: Displays the soft DIP switch settings screen. The DIP switches displayed on this page will vary depending on which games are active (see page 4 for a list of DIP switch settings).
- Video Test: Displays video test screens. Touch the screen to cycle through.
- Touchscreen Test: Enters the touchscreen test for checking touchscreen calibration.
- High-Scores: Enters the clear high scores screen. Touch game to select, touch “CLEAR CURRENT” to clear the high scores for that game. Touch “CLEAR ALL” to clear all high scores. Activate Six Stars* to clear high scores (*see next page).
- Clear Credit: Erases all credits on the machine.
- Free Credit: Adds credit without using coin switch. Free credits are listed separately in the books screen.
- System Settings: Enters the system settings screen which gives the operator access to the Set Time, Set Serial Game Number, PC Dump, Set 6 Star PIN, Security Setup, Volume Control, Video Billboard and Mega-Link screens. See the next page for explanations of each option.
- Exit: Returns the game to the attract mode.

To Enter This Screen, Touch “System Settings” At The Setup Screen



Figure 2 – System Settings Screen

System Settings

The System Settings controls allow the operator to access the Set Time, Set Serial Game Number, PC Dump, Set 6 Star PIN, Security Setup, Volume Control, Video Billboard and Mega-Link screens.

Set Time: Brings up the Set System Date and Time screen. Time is shown in 24-hour, military time (e.g. 5:00pm = 17:00). Use the up and down arrows to set the time and/or the date.

Set Game

Serial Number: Brings up the Set Game Serial Number screen. Enter the game's serial number using the keypad.

PC Dump: PC Dump allows the books information to be downloaded to a PC. Software for the PC is required for it to operate. Contact Merit Customer Service for information.

Set 6 Star PIN*: Brings up the Set 6 Star PIN screen via the info button in the games idle mode screen. Touch the stars in the order they must be touched to give access to the Video Billboard, High Scores, Volume Control and Calibration screens (to allow access to any of these screens through 6 Stars, the DIP switch must be set to “YES” for each screen; see the DIP switch list on page 1).

Security Setup: Brings up the Set Security PIN screen. From this screen, the operator can set the PIN number and select which of the features (Coin-In Menu, Game Menu, Display Books, Options, High Scores, Free Credits and Set 6 Star PIN) will be protected by the PIN. To set the PIN, first touch "SET" on the keypad. Then, enter your 4-digit PIN using the keypad and touch "ENTER." The game will prompt you to re-enter your PIN to confirm. After confirming your PIN, touch the icon for each of the features you wish to protect with the PIN.

To unlock a feature, touch the appropriate icon in the Set Up screen. The game will display the PIN keypad. Enter the PIN using the keypad. Once the PIN has been entered, all options become available (without having to enter the PIN for each option). After exiting the Set-Up screen, the PINs become active again for all appropriate options.

Volume: Brings up the Volume Control screen. Touch the volume control icon to adjust the volume up or down. This screen allows you to sample the sound volume without exiting the screen. The on-screen volume control can also be accessed using "Six Stars."

Video Billboard: See page 10 for Video Billboard operation instructions.

Mega Link Test: Allows the operator to test the connection between linked games.

****Six Stars Enabled***

This feature allows the access to the Clear High Scores, Volume Control, Video Billboard and Calibration, without having to remove the coin box. If the Six Stars Enabled dip switch is set to "YES," touching the INFO icon on the idle mode screen will cause six numbered stars to appear on the screen. Touching these stars in the programmed order will bring up a screen with icons for the Video Billboard, High Scores and Volume Control screens (provided the appropriate DIP switches have been set to "YES"). To set the sequence, in which the stars must be touched, go to the "System Settings" screen, touch the "Set Six Star PIN" icon and set the sequence.

To Enter This Screen, Touch “Game Menu” At The Setup Screen



Figure 3 - Game Menu Screen

The game list and prices are programmed using this screen. The top of the screen shows the various game menu names. The fields below show the game positions available, with the price for each game. The list on the right shows all games available for that category. The lower buttons will clear the selected item from the players’ game menu (CLEAR 1), clear all of the games from the players’ game menu (CLEAR), reset the selected game menu to the default setting (DEFAULT) and reset all of the game menus to the default settings (DEFAULT ALL).

To program the player’s game lists, first select the category in which you want the game to appear, by touching that category’s name at the top of the screen. Choose the menu position you want the game to occupy, by touching that position. Then, touch the desired game name, from the game list on the right side of the screen. That game will now appear in the menu (a game cannot appear in a game list more than once). To adjust the price, touch the price in the game menu. Each touch will rotate the price from 25¢ (1CR), to 50¢ (2CR), to 75¢ (3CR), to \$1 (4CR) and back to 25¢ (1CR). Touch “EXIT” when done.

TOP GAMES allows the operator to enter up to 6 games in that category. Set the Top Game Threshold to tell the game how many plays qualifies a game for the top games list. Once a game reaches that number of plays, it will automatically be added to the Top Games category. The Default threshold is “10.”

Games currently in the displayed category will appear shaded in the game list on the right.

To Enter This Screen, Touch “Coin-In Menu” At The Setup Screen



Figure 4 – Coin In Menu

Game cost can be controlled two ways: by changing the number of credits required to play a game or by changing the cost of a credit. The Coin-In Menu allows you to adjust the cost of a credit, as well as providing a way to give players “bonus” credits for depositing a higher amount of money.

In the example below (UK currency), each game costs one (1) credit and the cost for a single credit is 30p. This method is preferred if you want game cost to always be reflected as “1 credit.”

(COIN VALUE)	COIN INPUT	COINS	=	CREDITS	&	METER PULSES
(10p)	1E	3		1		3
(20p)	2E	3		2		6
(50p)	3E	1		2	(player premium 25p/credit)	5
(£1)	4E	1		5	(player premium 20p/credit)	10

Note that meter pulses are independent of credits and only track the unit of currency (10p in this example).

In the next example, the cost of a credit is set to 10p and each game costs 3 credits (for a total of 30p). This method allows game cost to be increased by the smallest unit of currency used (e.g. increasing the cost of Solitaire to four (4) credits would increase the game cost by 10p).

(COIN VALUE)	COIN INPUT	COINS	=	CREDITS	&	METER PULSES
(10p)	1E	1		1		1
(20p)	2E	1		2		2
(50p)	3E	1		6	(1 bonus credit)	5
(£1)	4E	1		15	(5 bonus credits)	10

In both examples, players are given an incentive to deposit more money by giving them “bonus” credits for depositing 50p or £1. Coins may be deposited in any combination of values and the game will automatically register the highest number of credits for the total amount of coins deposited. Once a game is played, any remaining fractional credits are erased.

When programming the Coin-In Menu, E1 is set for the lowest value coin, E2 for the next highest value, etc. If all four coin inputs are not used, the unused inputs must be set “N/A.” See the example below, which uses German currency.

(COIN VALUE)	COIN INPUT	COINS	=	CREDITS	&	METER PULSES
(1DM)	1E	1		1		1
(2DM)	2E	1		3	(1 bonus credit)	2
(5DM)	3E	1		7	(2 bonus credit)	5
(unused)	4E	N/A		N/A		N/A

Adjust the coin/credit/meter pulse settings by touching the field you want to change.

Generally, most countries have factory default setting. This setting can be adjusted (as described above), but will return if the game memory is cleared.

Some programs have a CURRENCY DEFAULT DISPLAY located to the left of the coin inputs. It shows the currency value for each of the coin inputs. This display is used as a guide and is not used in any calculations. Touch the CURRENCY DEFAULT DISPLAY to hide/show the display.

To Enter This Screen, Touch “Display Books” At The Setup Screen

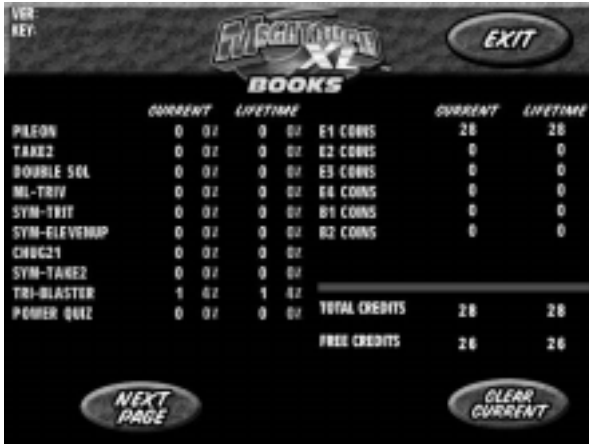

Figure 5 - Books Screen

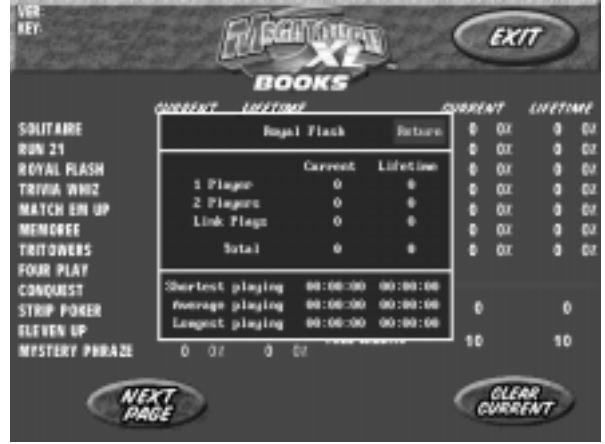

Figure 6 - Books Screen w/ Time Inset

The books screen displays the current and lifetime credit totals for each game, as well as the percentage of credits played per game (the percentage for each game is the total number of credits played on that game divided by the total number of credits entered into the machine).

Touching a game name will display the current and lifetime credit totals*, broken into 1 Player, 2 Player and Linked Games. It also shows the “shortest,” “longest” and “average” playing times for that game (only “link-only” games, like Pile-On, are included in time calculations; time calculations for mystery games that can be played as link or amusement are only displayed for the amusement version).

Touch CLEAR CURRENT to erase all current book data.

***Touching Trivia Whiz or Power Quiz displays totals by category.**

Megatouch™ XL Video Billboard Operating Instructions

The Megatouch™ XL Video Billboard allows for six, separate advertising screens. Two of the screens can only be accessed using “Six Stars” (and are intended for use by the location owner), the other four screens are accessed using the Video Billboard icon located on the System Settings screen.

The Video Billboard provides several font styles, sizes and colors, a choice of background colors and designs, as well as a variety of clip art. The basic Video Billboard screen is shown below, followed by the operating instructions. A maximum of 16 screen objects (a line of text or a piece of clip art) can be placed on any given screen.

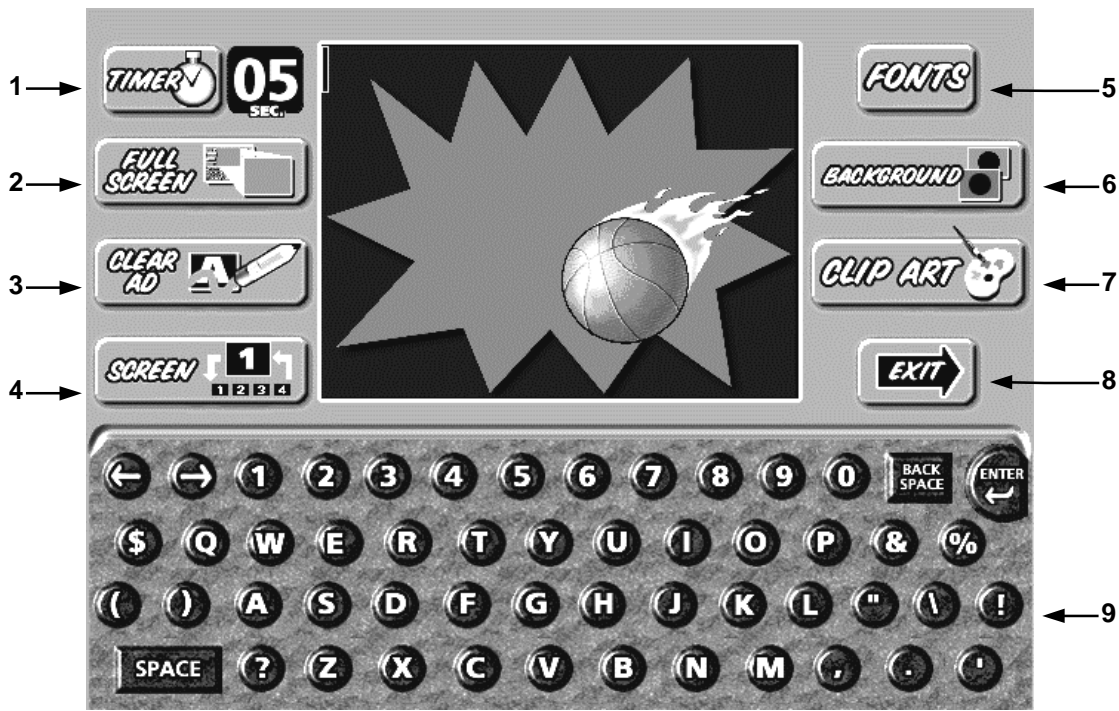

Figure 7 – Video Billboard Screen with Keyboard

To access the Video Billboard, enter the System Settings screen and touch the VIDEO BILLBOARD icon to display the video billboard keyboard screen.

Icon Functions:

Callout #	Screen Icon	Description of function
1	Timer	Allows the user to set the amount of time the given screen is displayed during the idle mode. The timer can be set from 0 to 20 seconds, in 5 second increments. (Setting the timer to zero (0) will prevent the screen from being displayed. This is helpful when designing a screen that you do not want to display immediately, but do want to store in the game's memory for use at a later date.)

Callout #	Screen Icon	Description of function
2	Full Screen	Allows the user to view a full screen preview of the designed screen. While in "full screen," graphics and text can be repositioned by selecting them and then touching the new location.
3	Clear Ad	Allows the user to erase the entire design for the displayed screen. This icon changes to "DELETE" if any screen object is selected (when an object is selected, a box appears around the object)
4	Screen X	Touching this icon toggles through each of the video billboard screens (where "X" is the number of the screen).
5	Font	Touching this icon displays the font formatting icons on the bottom half of the screen. These icons allow the user to select from 4 styles of font, 3 font sizes and 8 colors. The screen also has controls for alignment: right, left and centered. To format the font, select the desired text and then touch the font style, size, color and/or alignment (if you have more than one line of text on the screen, you will need to repeat this action for each line of text). Touching the KEYBOARD icon will return you to the keyboard screen.
6	Background	This icon toggles the background design through each of the 20 preset backgrounds.
7	Clip Art	This icon displays the clip art selection windows on the bottom half of the screen. From here, the user can select clip art to be used on the displayed screen. Use the scroll bar at the bottom of the screen to move through the clip art. To insert clip art, touch the screen at the desired location and then select the clip art. The clip art size can be adjusted by selecting the piece of clip art and then selecting "SMALL," "MEDIUM" or "LARGE" at the bottom of the screen (if you have more than one piece of clip art on the screen, you will need to repeat this action for each piece of clip art). Once clip art is displayed on the screen, touching the desired clip art and sliding your finger to the location where you want it placed can move it. Touching the KEYBOARD icon will return you to the keyboard screen.
8	Exit	Exits the user to the System Setting screen.
9	Keyboard	The keyboard is used for entering all text onto the displayed screen. Once text is displayed on the screen, touching the text and sliding your finger to the location where you want the text placed can move it. The cursor can be moved to a new location by touching the desired location.

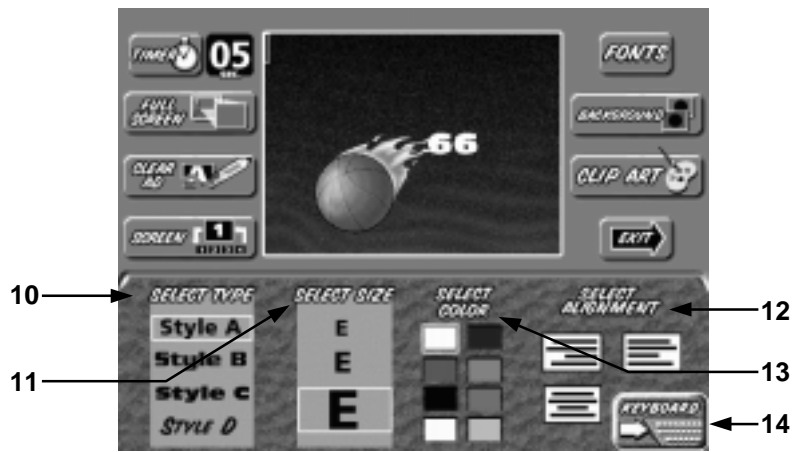

Figure 8 – Video Billboard Screen with Font Controls

Callout #	Screen Icon	Description of function
10	Select Type	Touch to change font type (choose from 4 font styles)
11	Select Size	Touch to change font size (choose from 3 size options)
12	Select Alignment	Touch to set font alignment (left, right or centered)
13	Select Color	Touch to change font color (choose from 8 colors)
14	Keyboard	Displays the keyboard



Figure 9 – Video Billboard Screen with Clip Art Controls

Callout #	Screen Icon	Description of function
15	Clip Art	Touch a clip art window to select (choose from 33 pieces of clip art)
16	Select Size	Touch to change clip art size (choose form 3 sizes)
17	Scroll Bar	Touch the arrows to scroll through the clip art
18	Keyboard	Displays the keyboard

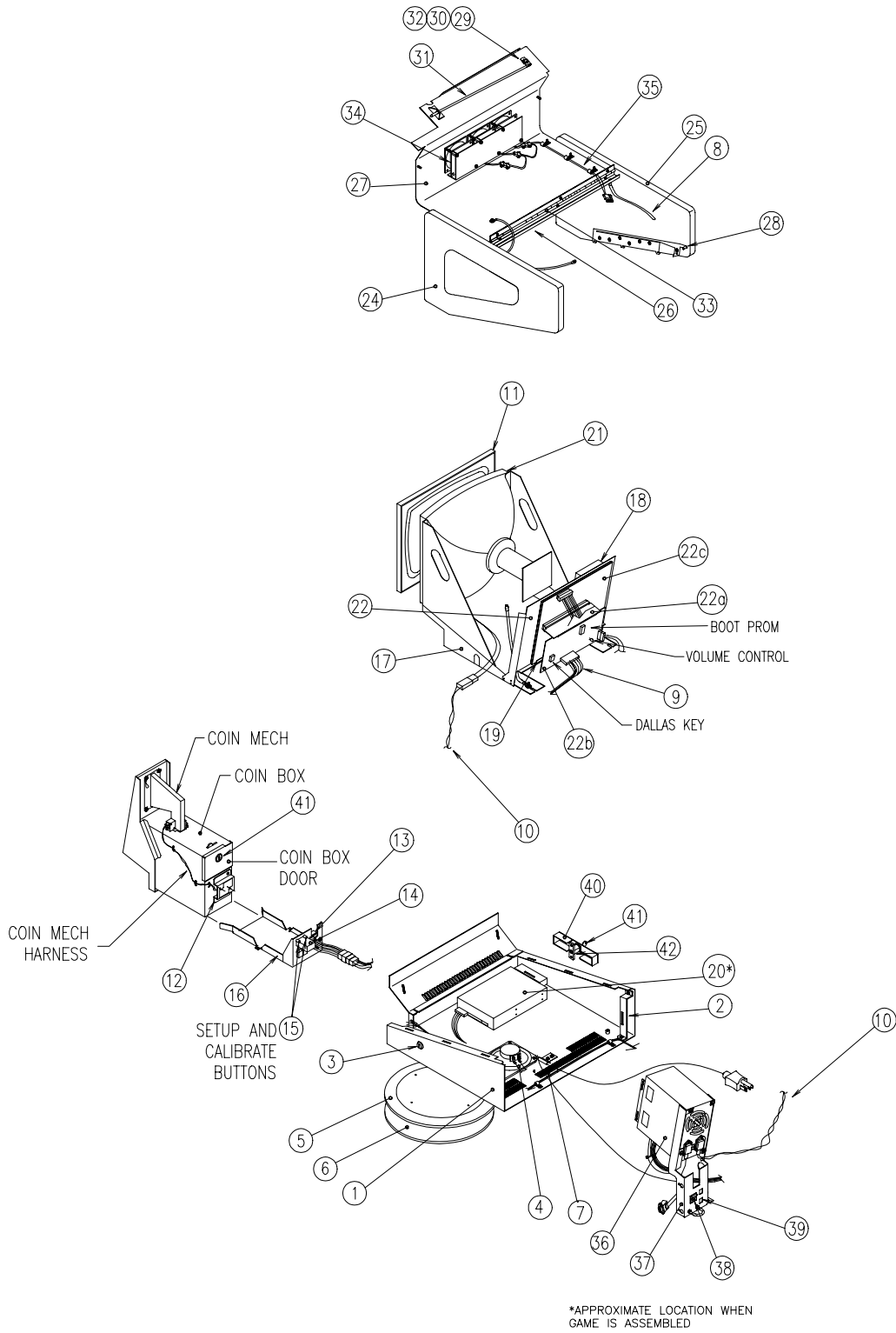

FIGURE 10 - 13" COUNTERTOP

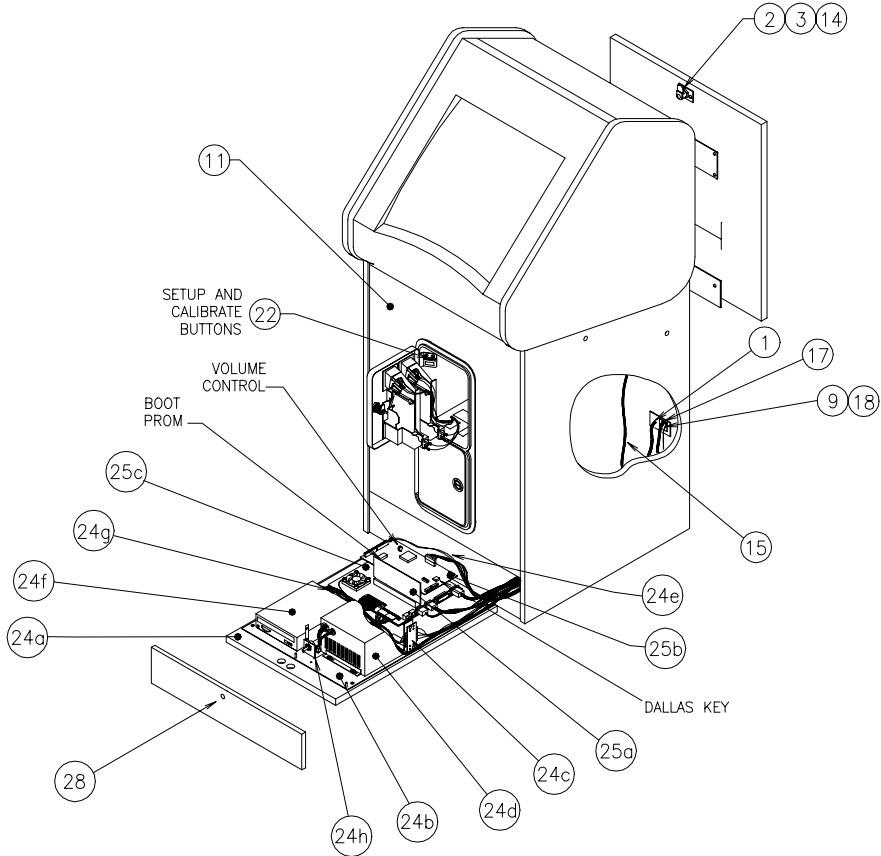

FIGURE 11 - 19" UPRIGHT (FRONT VIEW)

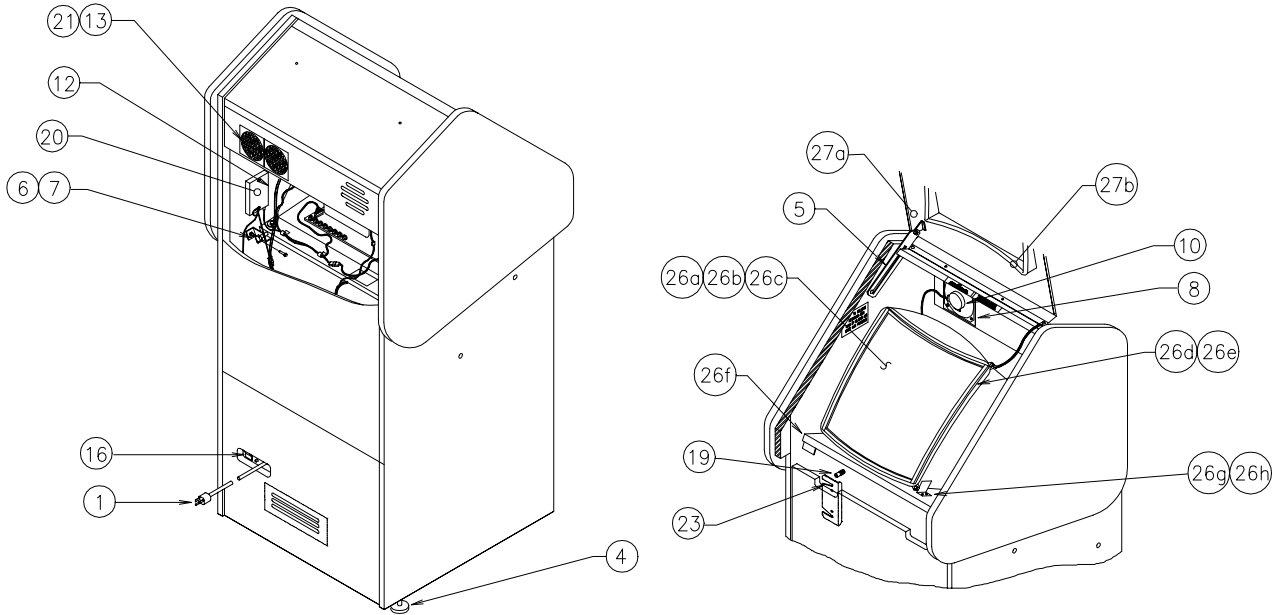

FIGURE 12 - 19" UPRIGHT (REAR VIEW)

FIGURE 13 - 19" CABARET (FRONT VIEW)

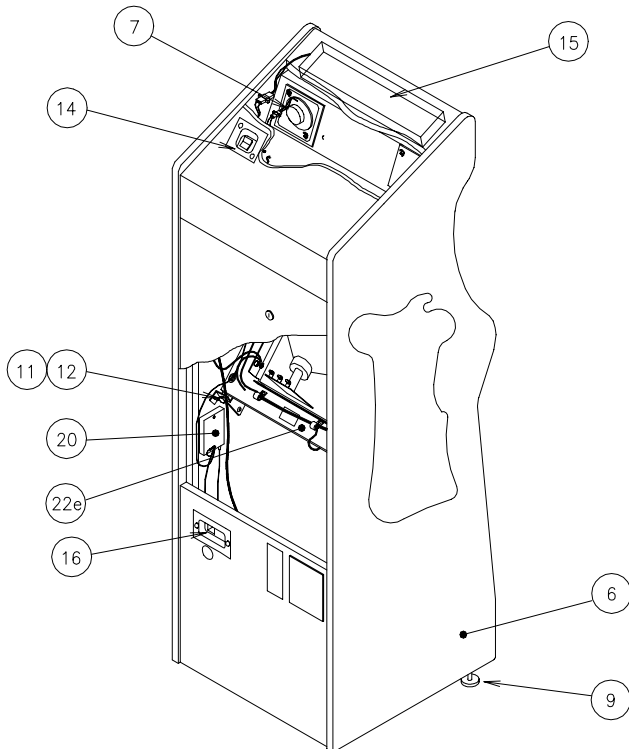
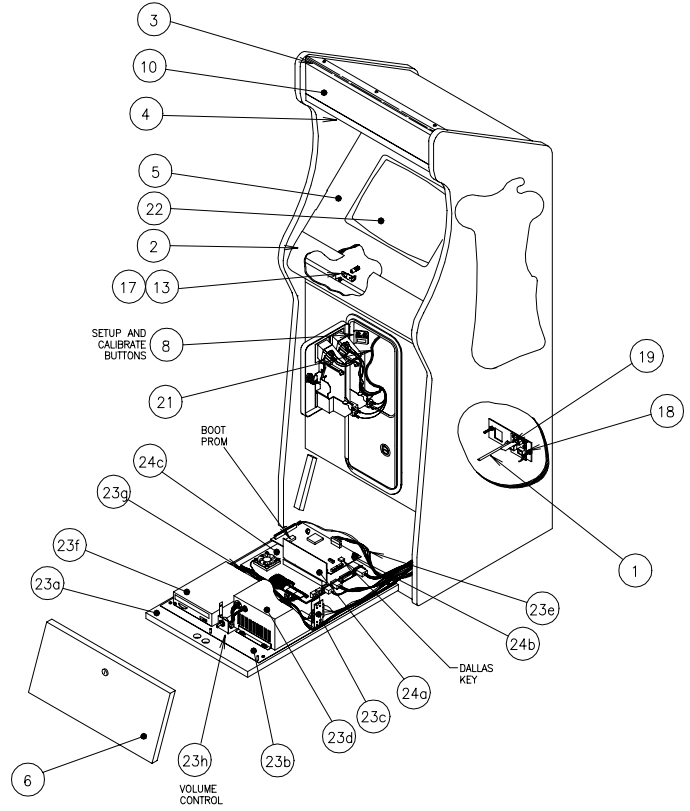

FIGURE 14 - 19" CABARET (REAR VIEW)

MEGATOUCH XL PARTS LISTS**Megatouch XL COP
Part List**

CALLOUT #	PART #	DESCRIPTION
	SA0100-01	ASSY, MEGATOUCH XL, CTOP
1	MW0009-01	CHASSIS, CTOP, XL
2	MW0015-01	BRACKET, LOCK, CTOP XL
3	HW8741	LOCK, CIRC, BNT, DIFF, 1/2"
4	SA4084-02	SPEAKER ASSY, 4", W/6-PIN CONN
5	HW8993-02	LAZY SUSAN, 12" DIA, 15 DEG. STOPS
6	HW8018-01	ANTI-SKID PAD, 11.5"DIA, RA65 RBR
7	MW0038-01	CORD CLAMP, XL
8	HW9001	TUBING, PLASTIC
9	SA0108-01	HARNESS, MAIN, CTOP, XL
10	SA0111-01	HARNESS, DISPLAY, AC, CTOP, XL
11	SA5129-01	GASKET/BEZEL ASSY
11a	HW8087	TAPE, NEOP, .18W X .38THK, PSA
11b	HW8953	BEZEL, 13' T/S
	SA0102-01	HARNESS, COIN BOX, MGATCH XL, CTOP
12	CN7508	METRIMATE PLUG, 12 PIN
13	CN7501	METRIMATE PIN, FEMALE 20-24 AWG
14	EC9154	COUNTER, 12V FROG EYE MTG
15	SW3005	PB SWITCH, MOMENTARY (SETUP/CALIBRATE)
16	MW0012-01	BRACKET, CONN/COUNTER, CTOP XL
	SA0104-01	DISPLAY/MOTHERBOARD ASSY, XL
17	MW0010-01	FRAME, DISPLAY, CTOP, XL
18	EC9840	TOUCHSCREEN CONTROLLER, SMT3
19	HW8171-01	PCB GUIDE, 8", SNAP-ON, DEEP CHANNEL
20	EC0003-01	CD-ROM PLAYER, IDE, 4X
21	SA0103-01	TOUCHSCREEN/VGA DSPLY ASSY, 13"
21a	EC9377	MONITOR, VGA, 13" (W/ CHASSIS BOARD & FRAME)
21b	EC9824	TOUCHSCREEN OVERLAY, 13'
21c	HW8078	TAPE, POLYESTER, 1", W/ADH
21d	HW8067	TAPE, FOAM, .5W X .03 THK, DBL
22	SA0112-01	ASSY, MOTHER BOARD & I/O, XL
22a	SA10025-01	PCA, CRT-402, DE-AMER, RISER BOARD
22b	SA10023-01	PCA, I/O BOARD, XL VID, CTOP
22c	SA0101-01	ASSY, MOTHERBOARD
23	SA0118-01	CABLE, POWER EXTENSION, CD-ROM
	SA0105-01	COVER ASSY, CTOP, XL
24	WD0001-01	SIDE PANEL, RIGHT, CTOP XL
25	WD0001-02	SIDE PANEL, LEFT, CTOP XL
26	MW0013-01	TOP, CTOP, XL
27	MW0016-01	DOOR, CTOP, XL
28	MW0014-01	PLATE, LATCH, CTOP, XL
29	HW8734-01	LOCK, W/O CAM, 564, 5/8"L (REAR DOOR)
30	MW0024-01	CAM, LOCK (REAR DOOR)
31	MW0023-01	BOLT, LOCK, CTOP, XL
32	HW8911-01	PIN, SPRING, STL, .094OD X .50L
33	MW5164-01	HINGE, REAR DOOR CTTS

34	EC9410	FAN, TUBAXIAL, 3", 110V
35	SA0117-01	CABLE, POWER EXTENSION, FAN
	SA0106-01	PWR ENTRY ASSY, CTOP, XL, 120V
36	EC7528	POWER SUPPLY, SW, PS/2-PC
37	MW0011-01	BARCKET, PWR SUPPLY, CTOP, XL
38	SW4024	ROCKER SW, DPST, 250V, PANEL MTG
39	TA10028-01	PCA, RS-485 COMMUNICATIONS BD, XL SYS
	SA0119-01	DOOR ASSY, CD-ROM ACCESS, XL, CTOP
40	MW0039-01	DOOR, CD-ROM ACCESS, XL, CTOP
41	HW8727	LOCK, FLAT, STR, DIFF, 1-1/8 CAPKY (CD DOOR/COIN BOX)
42	MW0037-01	CAM, LOCK, .75 X 2.0
DECALS AND SIGNS		
	GL3100-01	DECAL, SIDE PANEL, XL, CTOP
	GL3101-01	DECAL, FRONT, XL, CTOP
	SA7297-06	SIGN HOLDER, MEGATOUGH XL (HOLDER & SIGN ASSEMBLY)
	HW9461-03	SIGN HOLDER, PETG, 4 X 12, CTOP
	PM8928-09	SIGN, MEGATOUGH XL, CTOP
COIN MECHS/BILL ACCEPTORS		
<i>25¢ USA</i>		
	HW8249	FR/PLATE, SINGLE, M, .25, ROLL DOWN
<i>\$1 CANADIAN</i>		
	HW8295	FR/PLATE, SINGLE, M, \$1 CANADIAN
<i>COIN BOX ASSY</i>		
	SA5161-01	HARNESS, COIN BOX, MECHANICAL, CTOP, XL
	MW0017-01	COIN BOX, CTOP, XL
	MW5153-01	DOOR, COIN BOX, CTOP
		<i>COIN BOX/JCM B/A ASSY, \$1-20, XL</i>
	EC9797	JCM B/A DBV-45 \$1-20, W/ STACKER
	SA0109-01	HARNESS, JCM B/A, CTOP, XL

19" Upright Parts List

CALLOUT #	PART #	DESCRIPTION
1	EC2001	POWER CORD, 120V
2	HW8711	ANCHOR PLATE FOR CAM LOCK
3	HW8716	LOCK, FLAT, STR, #564, 1-7/16" (REAR DOOR)
4	HW8960	LEG LEVELER, 2", 3/8-16THD
5	MW5001-01	STAY LID, URTS, 19"
6	MW5003-01	BRACKET, CRT ADJUST, LEFT
7	MW5003-02	BRACKET, CRT ADJUST, RIGHT
8	MW5006-01	COVER, PERFORATED, SPEAKER, 4"
9	SB0010-01	COM, POWER CABLE
10	SA4084	SPEAKER ASSY, 4"
11	WD2017-01	CABINET, 19" URTS, XL/260, FA, BLK
12	SA0063-01	HARNESS, POWER, DUAL FANS, URTS
13	SA5117-05	FAN ASSY, 3", 12V DC, 2 PIN, W/GUARD
14	HW8756	CAM, BENT, 1/8" OFFSET
15	SA0094-01	CORD, IEC POWER x 42"
16	SW4024	ROCKER SWITCH, DPST, 250V, PNL MTG
17	TA10028-01	PCA, RS-485 COMM, XL SYS
18	EC2187-01	RIBBON CABLE, 9 COND, 31"L
19	HW6366	MOUNTING POST, KNURLED
20	EC9840	TOUCHSCREEN CONTROLLER BOARD, SMT-3
21	MW0057-01	COVER, FAN PROTECTOR
22	SA3209-01	BRACKET ASSY, METER/TEST SWITCH
23	MW0044-01	DOOR LOCK LATE, UR
24	SA3234-01 (-02)	SHELF, PC POWER, URTS, XL (-02 "CE" APPROVED ASSY)
24a	WD2018-01	SHELF, 19" VIDEO, UNIVERSAL
24b	MW0063-01	PLATE, MTG, PC/PWR, XL
24c	EC0007-01	TERMINAL BLOCK, 4 POSITION
24d	EC7528	POWER SUPPLY, SWT, PS-2/PC
24e	SA0077-01	HARNESS, MAIN, XL
24f	EC0003-01	CD-ROM PLAYER, IDE, 4X
24g	EC2191-06	RIBBON CABLE, 2X20 PIN, IDE, 7"L
24h	SA0067-01	HARNESS, VOLUME POT, URTS/CAB, 260
25	SA0112-01	ASSY, MOTHERBOARD & I/O, XL
25a	SA10025-01	PCA, CRT-402, DE-AMER, RISER BOARD
25b	SA10023-01	PCA, I/O BOARD, XL VID, CTOP
25c	SA0101-01	ASSY, MOTHERBOARD
26	SA3202-05	SHELF ASSY, TS/CRT (VGA)
26a	SA3210-03	TS/CRT (VGA) ASSY, COLOR, 19"
26b	EC9378	MONITOR, VGA, 19"
26c	EC9823	T/S OVERLAY, 19"
26d	HW8078	TAPE, POLYESTER, 1", W/ADHESIVE
26e	HW8067	TAPE, FOAM, .5W, .03THK, DBL
26f	WD2013-01	SHELF, CRT MTG, 19" URTS
26g	MW5008-01	BRACKET, CRT LEFT, 19" URTS
26h	MW5008-02	BRACKET, CRT RIGHT, 19" URTS
27	SA3230-01	BEZEL ASSY, 19" URTS
27a	MW5014-01	BEZEL/HINGE ASSY, 19" URTS
27b	HW8951-02	BEZEL, MONITOR, 19" URTS
28	HW8713	LOCK, FLAT, STR, 564, 1-7/16 KYRM

19" Cabaret Parts List

CALLOUT #	PART #	DESCRIPTION
1	EC2001	POWER CORD, 120V
2	MW1672-01	CONTROL PANEL, 19" CABARET
3	MW1671-01	BRKT, GLASS, UPPER, 19" CABARET
4	MW1670-01	SPEAKER, MTG BRKT, 19" CAB
5	HW8951-01	BEZEL, MONITOR, 19" CABARET
6	WD5060-01	WOOD CABINET, URTS, 19" CABARET
7	SA4084	SPEAKER ASSY, 4"
8	SA3209-01	BRACKET ASSY, METER/TEST SWITCH
9	HW8960	LEG LEVELER, 2", 3/8-16THD
10	GL2411-03	PLEXI, CLEAR, 19" CABARET, SIGN
11	MW1674-01-0A	MONITOR, SUPPORT LEFT, 19" CABARET
12	MW1674-02-0A	MONITOR, SUPPORT RIGHT, 19" CABARET
13	HW8979	SLIDE LATCH
14	SA0058-01	HARN, PWR SWITCH, URTB/URTS/CAB, XL
14a	SW4024	ROCKER SWITCH, DPST, 250V, PNL MTG
15	SB6058-01	FLUOR LAMP ASSY, 120V/60HZ, 15W
15a*	LB2100	LAMP, FLUOR, 15W, F15T8CW
16	MW0028-01	PLATE, POWER ENTRY
17	HW6366	MOUNTING POST, KNURLED
18	TA10028-01	PCA, RS-485 COMM, XL SYS
19	EC2187-01	RIBBON CABLE, 9 COND, 31"L
20	EC9840	TOUCHSCREEN CONTROLLER BOARD, SMT-3
21	SA0014-01	HARN, E/M/CREJ, 19" CABARET
22	SA3266-03-0B	CRT ASSY, 19" CABARET, XL
22a*	EC9378	MONITOR, VGA, 19"
22b*	EC9823	T/S OVERLAY, 19"
22c*	HW8078	TAPE, POLYESTER, 1", W/ADHESIVE
22d*	HW8067	TAPE, FOAM, .5W, .03THK,DBL
22e	WD5061-01-0A	SHELF, MONITOR, 19" CABARET
23*	SA3234-01 (-02)	SHELF, PC POWER, URTS, XL (-02 "CE" APPROVED ASSY)
23a	WD2018-01	SHELF, 19" VIDEO, UNIVERSAL
23b	MW0063-01	PLATE, MTG, PC/PWR, XL
23c	EC0007-01	TERMINAL BLOCK, 4 POSITION
23d	EC7528	POWER SUPPLY, SWT, PS-2/PC
23e	SA0077-01	HARNESS, MAIN, XL
23f	EC0003-01	CD-ROM PLAYER, IDE, 4X
23g	EC2191-06	RIBBON CABLE, 2X20 PIN, IDE, 7"L
23h	SA0067-01	HARNESS, VOLUME POT, URTS/CAB, 260
24*	SA0112-01	ASSY, MOTHERBOARD & I/O, XL
24a	SA10025-01	PCA, CRT-402, DE-AMER, RISER BOARD
24b	SA10023-01	PCA, I/O BOARD, XL VID, CTOP
24c	SA0101-01	ASSY, MOTHERBOARD

*This part is not called out in the drawing. It is either part of an assembly that is shown, or it is an assembly in which all of the parts are shown separately.

Merit Video Limited Warranty

Merit Industries, Inc. warrants its video countertop and upright machines to be free from defects in material and workmanship for a period of six months from the date of delivery or seven months from the date of shipment from its facilities, whichever occurs first. The warranty covers all electrical components (except fuses and light bulbs) and printed circuit boards. Other items are covered by warranty periods offered by the original equipment manufacturers (power supplies - 90 days; video monitors - 90 days).

Failure due to misuse, vandalism, excessive or intentional abuse, operation outside specified conditions (including, but not limited to, improper electrical power source), fire, water damage, acts of God, acts of war and civil unrest are specifically excluded.

Merit products are carefully inspected and thoroughly tested prior to packing and shipment. Any damage discovered upon receipt of goods, whether obvious or concealed, must be reported immediately to the delivering carrier and claims made directly to them. Merit assumes no responsibility for damages once the product has left its facilities and any disputes regarding transportation damage must be resolved with the shipping company(s).

Merit will repair or replace, at its option, any component, part or assembly that fails under warranty, provided that the failed item is returned, shipping charges prepaid, to Merit's repair facility and Merit is notified of the failure within the warranty period. Merit reserves the right to request the serial numbers of the item and/or game which has failed, and copies of sales invoices, bills of lading or other documents as required to determine the validity of the warranty coverage. Merit will return or replace warranty items, as specified above, shipping charges prepaid, by ground transportation.

Merit's obligation shall be limited to repair or replacement as stated above, and shall specifically exclude any liability for consequential damages or loss of earnings.

Merit may, at its discretion, provide replacement parts under warranty prior to receiving defective items without incurring any ongoing obligation to extend such accommodations.

In certain instances, due to geographical or other considerations, Merit may offer PCB warranty service on an extended time basis as follows:

- (a) User notifies Merit in writing (or FAX) of PCB failure, providing dates of failure, serial numbers and a brief description of failure symptoms.
- (b) Failed PCBs are accumulated for a time period or quantity accumulation, as designated by Merit and sent in one shipment to save shipping expenses.
- (c) Merit honors warranty as per dates of failure notification.

The above terms and conditions constitute the sole obligation, written or implied, of Merit Industries under its warranty coverage.

PROPRIETARY

THE INFORMATION CONTAINED HEREIN IS THE EXCLUSIVE PROPERTY OF MERIT INDUSTRIES, INCORPORATED AND SHALL NOT BE USED, DISTRIBUTED OR REPRODUCED IN WHOLE, OR IN PART, WITHOUT THE EXPRESS WRITTEN PERMISSION OF MERIT INDUSTRIES, INCORPORATED.

FCC WARNING

THIS EQUIPMENT COMPLIES WITH THE REQUIREMENTS IN PART 15 OF FCC RULES FOR A CLASS "A" COMPUTING DEVICE. OPERATION IN A RESIDENTIAL AREA MAY CAUSE INTERFERENCE TO RADIO AND TV RECEPTION REQUIRING THE OPERATOR TO TAKE WHATEVER STEPS ARE NECESSARY TO CORRECT THE INTERFERENCE.